

DRIP COVER FURNISHED AS STANDARD

NOTES:

- ① ALWAYS REMOVE COUPLING GUARD (240) BEFORE LIFTING UNIT, FILLING WITH OIL OR SERVICING. (4) QUICK RELEASE LATCHES ARE PROVIDED.
 - ② 3/4 NPT OIL FILL PLUG
 - ③ NO PERIODIC GREASE RELUBRICATION IS REQUIRED EXCEPT FOR THE MOTOR BEARINGS. ALL GEAR DRIVE BEARINGS ARE OIL SPLASH LUBRICATED. THE HIGH SPEED COUPLING DOES NOT REQUIRE LUBRICANT.
- REFER TO YOUR INSTRUCTION MANUAL FOR COMPLETE LUBRICANT SPECIFICATIONS & DETAILS.
- ④ ITEMS 201/202 SOLD AS AN ASSEMBLY ONLY ON UNIT SIZE 14 & 15. ITEM 202 SOLD SEPARATELY ON UNIT SIZE 16 ONLY.
 - ⑤ QUANTITY IS TWO FOR UNIT SIZE 14 & 15, AND THREE FOR UNIT SIZE 16.

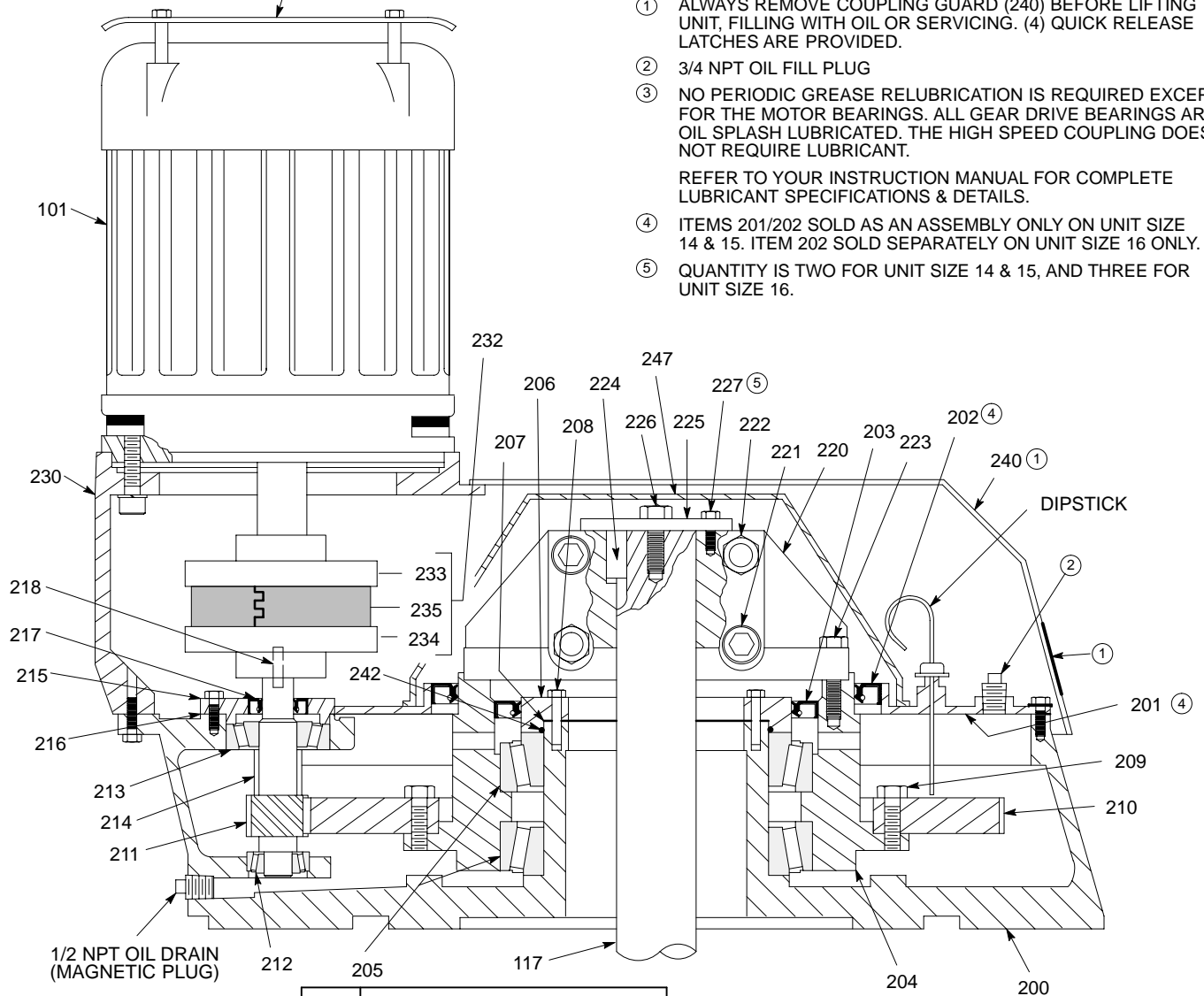

215	HIGH SPEED BEARING RETAINER	247	COUPLING SHIELD
214	SPACER (UNIT SIZE 16 ONLY)	242	O-RING
213	HIGH SPEED BEARING - UPPER	240	COUPLING GUARD
212	HIGH SPEED BEARING - LOWER	235	FLEXIBLE ELEMENT - SPLIT
211	HIGH SPEED PINION & SHAFT	234	DRIVEN HUB - PINION SHAFT
210	LOW SPEED GEAR	233	DRIVE HUB - MOTOR SHAFT
209	HEX HD. CAP SCREW (NYLOK)	232	H.S. FLEXIBLE COUPLING ASSY
208	HEX HD. CAP SCREW (NYLOK)	230	MOTOR PEDESTAL
207	SHIM SET - L.S. BEARING ADJUSTMENT (10 PER SET)	227	HEX HD. CAP SCREW (5)
206	LOW SPEED BEARING RETAINER	226	HEX HD. CAP SCREW (1)
205	LOW SPEED BEARING (2)	225	THRUST PLATE
204	LOW SPEED GEAR HUB	224	KEY - IMPELLER SHAFT
203	OIL SEAL - INNER	223	HEX HD. CAP SCREW (NYLOK) (8)
202	OIL SEAL - OUTER (4)	222	HEX NUT (4)
201	HOUSING COVER (4)	221	SOCKET HD. CAP SCREW (4)
200	GEAR DRIVE HOUSING	220	LOW SPEED COUPLING - SPLIT
117	IMPELLER SHAFT	218	KEY - PINION SHAFT
101	MOTOR	217	OIL SEAL - HIGH SPEED
		216	SHIM SET - H.S. BEARING ADJUSTMENT (6 PER SET)
ITEM	PART NAME	ITEM	PART NAME

WHEN ORDERING PARTS, SPECIFY; MODEL, SERIAL NUMBER, ITEM NUMBER AND DRAWING NUMBER.

ALL EQUIPMENT DESIGN AND APPLICATION DATA SHOWN HEREIN AND RELATED KNOW-HOW IS CONFIDENTIAL AND THE PROPERTY OF THE LIGHTNIN GROUP OF COMPANIES. NO USE OR DISCLOSURE THEREOF MAY BE MADE WITHOUT OUR WRITTEN PERMISSION.



© LIGHTNIN 1994

LIGHTNIN

MIXERS AND AERATORS
ASSEMBLY DRAWING

SERIES 10™
UNIT SIZE 14, 15 & 16
OPEN TANK MIXER