

D RIP COVER FURNISHED WITH EXPLOSION PROOF MOTORS ONLY

NOTES:

- ① NO PERIODIC GREASE RELUBRICATION IS REQUIRED EXCEPT FOR THE MOTOR BEARINGS. ALL GEAR DRIVE BEARINGS ARE OIL SPLASH LUBRICATED OR GREASED FOR LIFE. REFER TO YOUR INSTRUCTION MANUAL FOR COMPLETE LUBRICANT SPECIFICATIONS AND DETAILS.

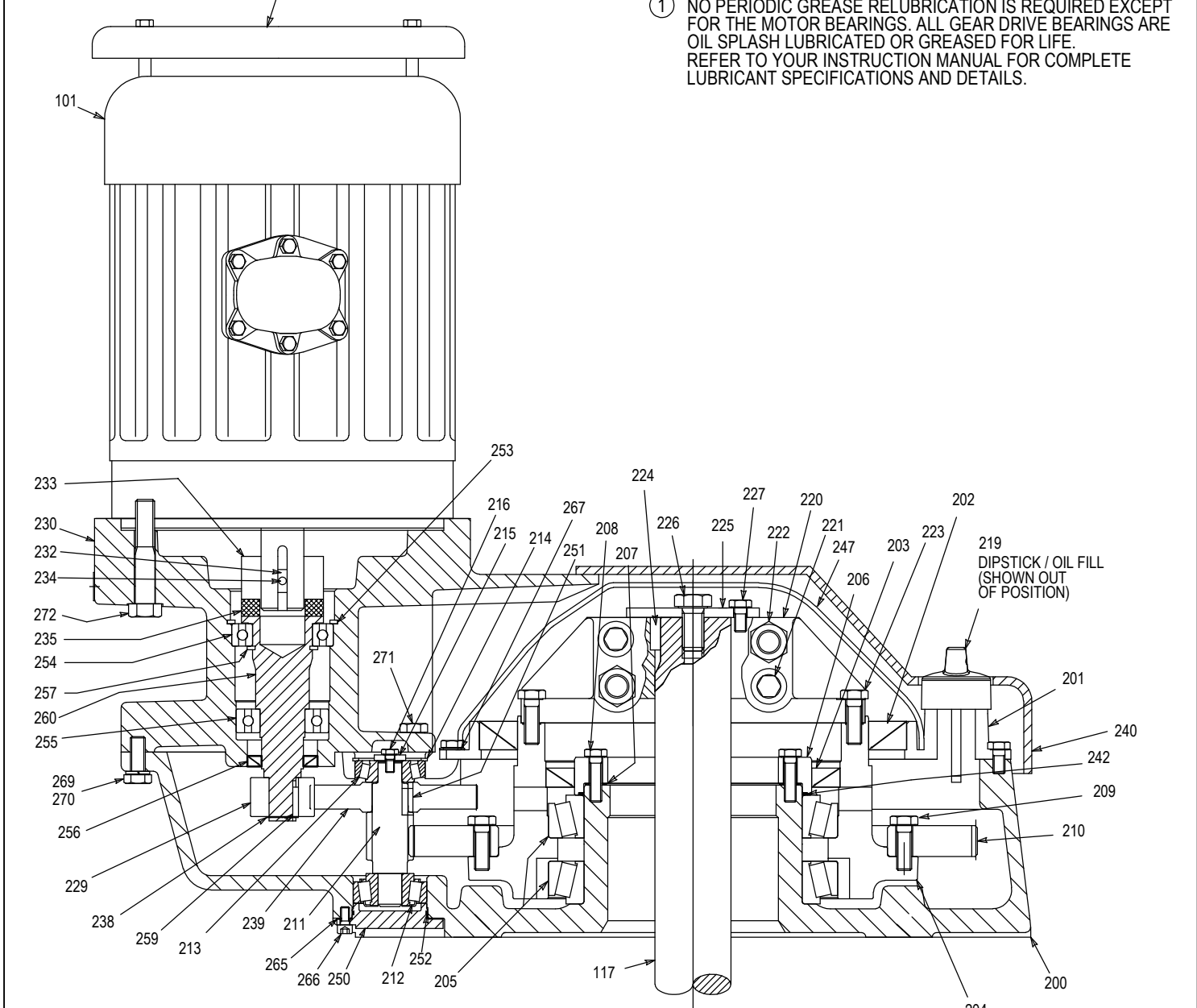

229	HIGH SPEED PINION
227	HEX HEAD CAP SCREW (4)
226	HEX HEAD CAP SCREW (1)
225	THRUST PLATE
224	KEY - IMPELLER SHAFT
223	HEX HEAD CAP SCREW - NYLOK (8)
222	HEX NUT (4)
221	SOCKET HEAD CAP SCREW (4)
220	LOW SPEED COUPLING - SPLIT
219	DIPSTICK
216	HEX HEAD CAP SCREW
215	THRUST WASHER
214	RETAINING RING
213	LOW SPEED BEARING - UPPER
212	LOW SPEED BEARING - LOWER
211	LOW SPEED PINION & SHAFT
210	LOW SPEED GEAR
209	HEX HEAD CAP SCREW - NYLOK
208	HEX HEAD CAP SCREW - NYLOK
207	SHIM SET - LOW SPEED BEARING
206	ADJUSTMENT (10 PER SET)
205	LOW SPEED BEARING RETAINER
204	LOW SPEED BEARING (2)
203	LOW SPEED GEAR HUB
202	OIL SEAL - INNER
201	OIL SEAL - OUTER
200	DRIVE COVER
117	GEAR DRIVE HOUSING
101	IMPELLER SHAFT
101	MOTOR

272	HEX HEAD CAP SCREW (4)
271	HEX HEAD CAP SCREW (2)
270	LOCKWASHER (5)
269	HEX HEAD CAP SCREW (5)
267	PLAINWASHER (2)
266	SOCKET HEAD CAP SCREW (6)
265	SHIM SET - LOW SPEED PINION SHAFT
260	ADJUSTMENT (6 PER SET)
259	HIGH SPEED SHAFT
257	KEY - HIGH SPEED PINION
256	RETAINING RING
255	OIL SEAL - HIGH SPEED
254	HIGH SPEED BEARING - LOWER
253	HIGH SPEED BEARING - UPPER
252	RETAINING RING
251	O-RING
250	KEY - LOW SPEED PINION SHAFT
247	BEARING RETAINER
246	COUPLING SHIELD
245	O-RING
240	SAFETY GUARD
239	INTERMEDIATE GEAR
238	RETAINING RING
235	FLEXIBLE ELEMENT
234	SET SCREW
233	HIGH SPEED SHAFT HUB
232	MOTOR KEY
230	DRIVE PEDESTAL

WHEN ORDERING PARTS, SPECIFY:
MODEL & SERIAL NUMBER, ITEM
NUMBER AND DRAWING NUMBER

ALL EQUIPMENT DESIGN AND APPLICATION DATA SHOWN HEREIN AND RELATED KNOW-HOW ARE CONFIDENTIAL AND PROPRIETARY AND REMAIN THE PROPERTY OF SPX CORPORATION. NO USE OR DISCLOSURE THEREOF MAY BE MADE WITHOUT THE WRITTEN PERMISSION OF SPX CORPORATION.

LIGHTNIN

AN SPX BRAND

ASSEMBLY DRAWING

SERIES 10 - 50HZ & 60HZ
NEMA FRAME
UNIT SIZE 16
DOUBLE REDUCTION



COPYRIGHT © 2010
SPX CORPORATION