

>Lightnin®



ENHANCED CLASSIC LINE (ECL) MIXERS

Portable/Fixed Mount Mixers



SPXFLOW®

THE HIGHEST PERFORMANCE, QUALITY RANGE OF PORTABLE MIXERS

The Lightning Classic mixers have consistently evolved and improved through the years. These upgrades have provided our customers with improved mixer performance and enhanced process results.

Now the Enhanced Classic Line (ECL) portable mixers give our customers an even stronger and more flexible product. Never before has there been a range of portable mixers offering so much quality and value. The ECL product range is designed to meet OSHA, CE, and ATEX standards.

Maintenance Free Operation

All shaft bearings are sealed for life. Gears are synthetic grease lubricated for continuous lifetime service.

ECL Motor Options:

- **Electric Motors:** A variety of enclosures, single or three phase, multiple voltage, and severe duty options are also available
- **Air Motors:** Variable speed air motors are safe for explosive environments. They are supplied with a built-in speed adjustment, air control valve and an option for non-lubricated vanes. Options include air filters, lubricators, and pressure regulators



SANITARY UPGRADE OPTIONS

- Food Grade Paint
- IP56 Washdown Motors (Painted and Stainless Options Available)
- Seals with FDA Acceptable Materials and USP Class VI Elastomers
- Quality Assurance Documentation
- Food Grade Grease
- Polish
- EP

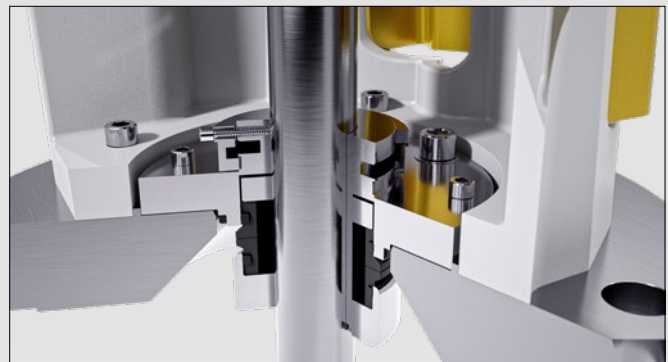

Sanitary ESH Seal

THEORY OF OPERATION

Maintenance free operation. All shaft bearings are sealed for life. Gears are synthetic grease lubricated for continuous lifetime service.

A mixer duty motor with standard mounting allows for many speed and enclosure variations.

Aluminum housing designed for high strength and low weight.

Large output shaft bearings for longer allowable shaft lengths and long life.

Safe positive chuck design prevents the shaft from disconnecting unless intentionally released. All hardware is captive to the chuck preventing loss.

The A310 is designed to produce excellent flow and process results at less power than other axial flow impellers.

Unique motor coupling protects the gearing from shock torque loads and increases motor bearing life.

Two interchangeable planetary gear ratios provide more output speeds and increased process flexibility. Direct drive also available.

Multiple bearing seals prevent leakage of lubricant.

A convenient clamp indexing and locking system ensures precise, repeatable positioning for your unique application.

Strong, rugged clamp with slotted stabilizing wings and four point clamping for secure hold to the tank.

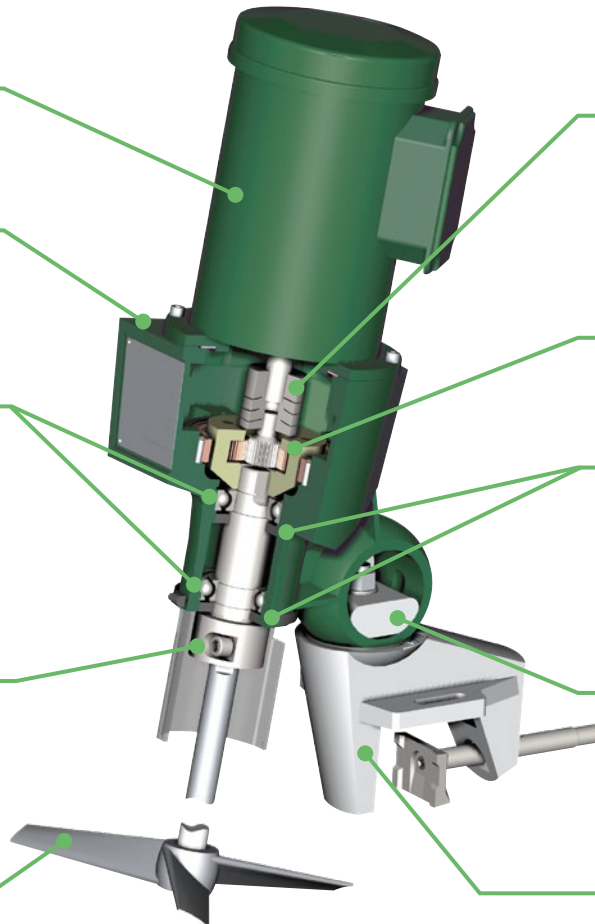

ECL Portable Mounting Options:

- A Finite Element Analysis designed heavy-duty clamp assembly provides maximum strength
- The cup plate option offers a more permanent mounting
- Clear index allows repeatable position
- Four point clamp action for secure hold on tank

ECL Portable Options:

- Stainless steel housing for clean applications on portable mounts
- Rigid coupling shaft attachment with male/female pilot to ensure shaft concentricity and minimize shaft run out
- Tachometer can be mounted remotely and provide a display of mixer output speed. A 4 to 20mA output signal is available for process control
- Variable speed control - VFD

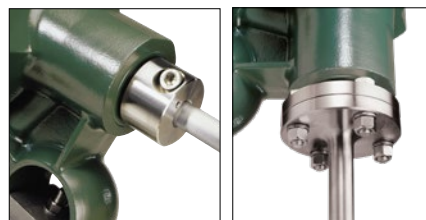

CLOSED TANK UNIT

Rigid-removable coupling above seal for ease of maintenance. Piloted fit to minimize shaft run out.

Mechanical seal, stuffing box and lip seal options available.

Solid 316 stainless steel ANSI and DIN flanges as standard. Other materials available upon request.

Separate bearing support minimizes shaft deflection at seal for longer life.

All sealing devices are completely interchangeable, allowing easy field retrofit and reducing inventory.

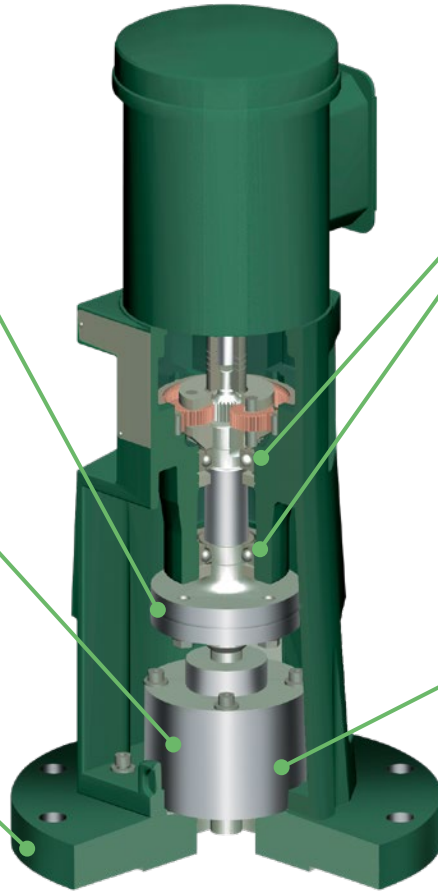

ECL SEALING Options:

- Packing: Lubricated, non-lubricated or food grade
- Single Seal: Dry running, lubricated or sanitary
- Double Seal: Dry running, lubricated or gas lift-off
- Seal Lubricators: Provide proper lubrication of seal faces
- Lip Seal: Multiple material options available



OPEN TANK UNIT

Maintenance free operation. All shaft bearings are sealed for life. Gears are synthetic grease lubricated for continuous lifetime service.

A mixer duty motor with standard mounting allows for many speed and enclosure variations.

Aluminum housing designed for high strength and low weight.

Large output shaft bearings for longer allowable shaft lengths and long life.

Rigid coupling shaft attachment with pilot fit to ensure shaft concentricity and minimize shaft run out.

The A310 is designed to produce excellent flow and process results at less power than other axial flow impellers. Other impeller types available.

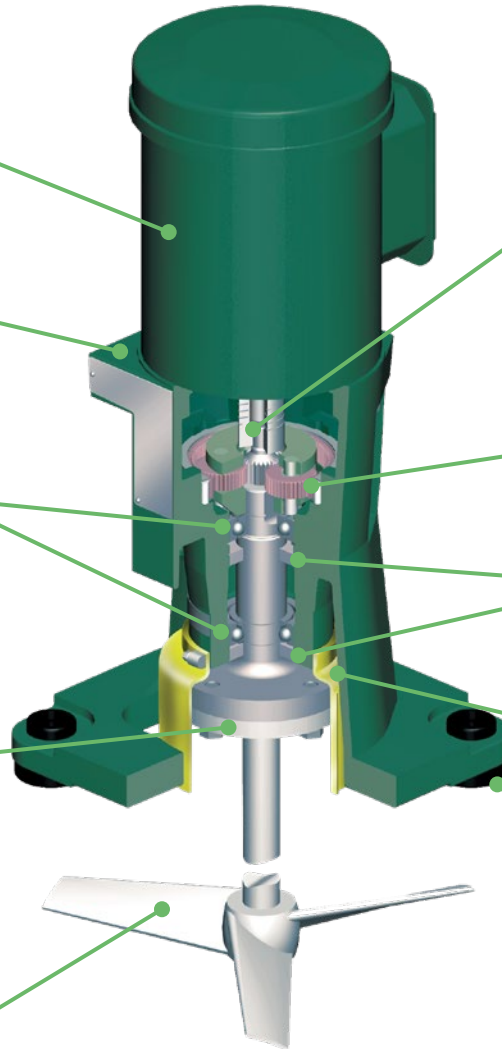

Unique motor coupling protects the gearing from shock torque loads and increases motor bearing life.

Two interchangeable planetary gear ratios provide more output speeds and increased process flexibility. Direct drive also available.

Multiple bearing seals prevent leakage of lubricant.

OSHA and CE compliant coupling guard.

Isolation Mounts protect drive against high fluid forces.



ATEX is applicable for all machine types for this product line:

- Portable
- Fixed Mount
- Open Tank

ECL fixed mount options:

- Remote Tachometer provides a LCD display of mixer output speed. A 4 to 20 mA output signal is available for process control.
- Variable speed control - A variety of voltage, NEMA, and IP enclosure options are available.
- Angle riser available on open tank units for off-center positioning of mixer.
- Closed tank flange options - ANSI150lb. and DIN-PN10 solid stainless steel flange as standard. Oversized and sanitary available upon request.



With every agitator purchase, Lightnin customers receive a product that has the built-in value of years of mixing experience in almost every known fluid mixing application.

Portable ECL gear and direct drive

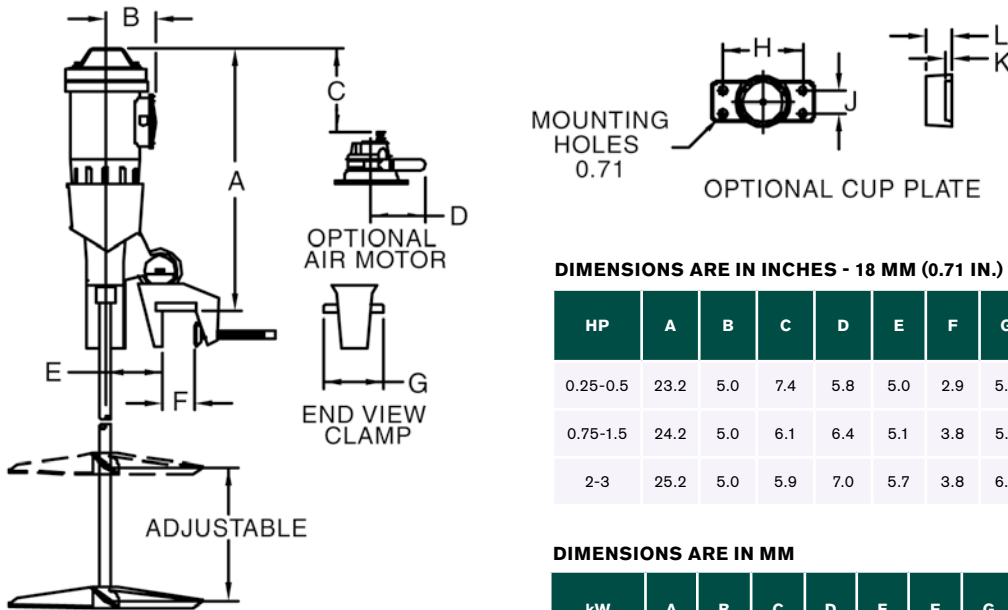

MOUNTING HOLES 0.71

OPTIONAL CUP PLATE

DIMENSIONS ARE IN INCHES - 18 MM (0.71 IN.)

HP	A	B	C	D	E	F	G	H	J	K	L	APPROX. WEIGHT (LBS.)
0.25-0.5	23.2	5.0	7.4	5.8	5.0	2.9	5.3	7.0	2.0	0.5	2.2	81
0.75-1.5	24.2	5.0	6.1	6.4	5.1	3.8	5.7	8.5	2.0	0.7	2.4	122
2-3	25.2	5.0	5.9	7.0	5.7	3.8	6.9	8.5	2.5	0.7	3.0	185

DIMENSIONS ARE IN MM

kW	A	B	C	D	E	F	G	H	J	K	L	APPROX. WEIGHT (kg.)
0.25-0.37	550	101	151	85	127	67	134	178	51	12	87	34
0.75-1.5	650	145	185	104	130	89	143	216	51	18	102	55

Open tank ecl gear and direct drive

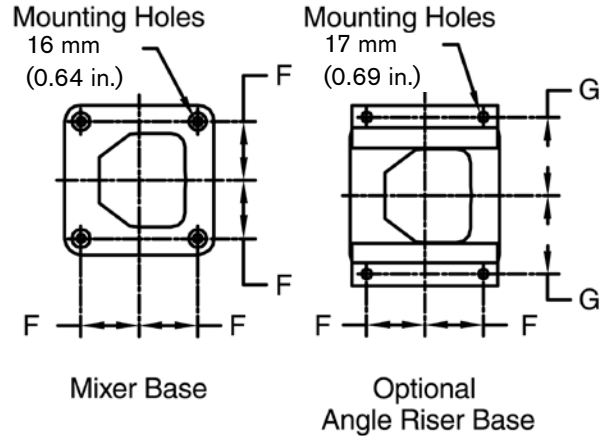
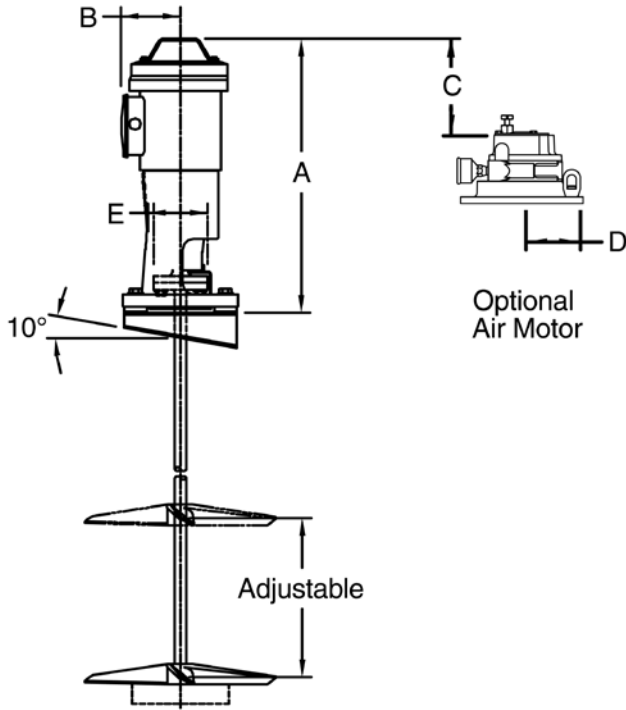

DIMENSIONS ARE IN INCHES

HP	A	B	C	D	E	F	G	APPROX. WEIGHT (lbs.)
0.25-0.5	24.4	5.3	7.4	5.8	4.8	4.0	5.5	131
0.75-1.5	25.3	5.3	6.1	6.4	4.8	4.5	5.9	182
2-5	26.2	5.3	5.9	7.0	4.8	5.5	7.6	266

DIMENSIONS ARE IN MM

kW	A	B	C	D	E	F	G	APPROX. WEIGHT (kg.)
0.25-0.37	650	101	213	85	121	102	136	63
0.75-1.5	700	145	225	104	121	114	149	86
1.1-4.0	800	196	302	104	121	140	194	124

Closed tank ECL gear and direct drive

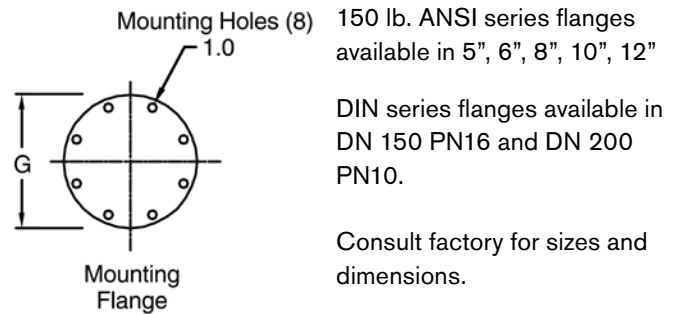
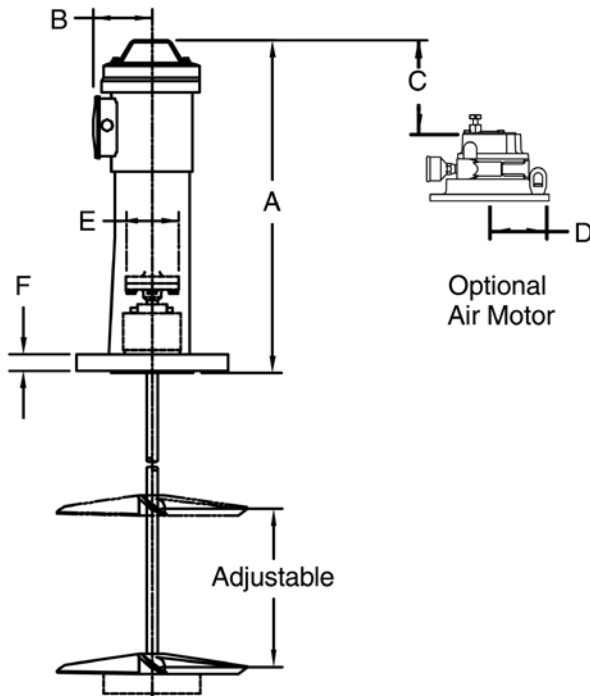

DIMENSIONS ARE IN INCHES

HP	A	B	C	D	E	F	APPROX. WEIGHT (lbs.)
0.25-0.5	29.8	5.3	7.4	5.8	4.8	1.7	183
0.75-1.5	31.8	5.3	6.1	6.4	4.8	1.7	234
2-5	32.8	5.3	5.9	7.0	4.8	1.7	318

DIMENSIONS ARE IN MM

kW	A	B	C	D	E	F	APPROX. WEIGHT (kg.)
0.25-0.37	650	101	213	85	121	102	63
0.75-1.5	915	145	245	104	121	32	86
1.1-4.0	1000	196	305	104	121	32	144



IMPELLER OPTIONS

Lightnin is the world leader of impeller development. Using the latest computerized technology, Lightnin has produced a unique range of impellers dedicated to improving your specific process performance. Although the A310 is standard on ECL portables, there are many other impellers to satisfy your mixing requirements. Your Lightnin Sales Engineer will review your application and recommend the proper impeller.



A100



A310-A510



A320



A200

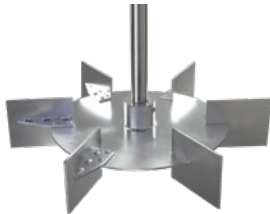

R100



Folding Impeller



R500



Clean-Edge



SPX FLOW, Inc. reserves the right to incorporate our latest design and material changes without notice or obligation. Design features, materials of construction and dimensional data, as described in this bulletin, are provided for your information only and should not be relied upon unless confirmed in writing. Please contact your local sales representative for product availability in your region. The green “>” is a trademark of SPX FLOW, Inc.

For more information, visit www.spxflow.com.